

## GENERAL DESCRIPTION

DAB Pumps are proud to officially launch the second phase of our brand new innovative booster product to the UK market, leading the way in electronic pump technology.

The E.SYTWIN is a completely new solution in cold water boosting for residential and light commercial applications.

Essentially a twin pump, water cooled booster pump with integrated high efficiency variable speed motor,

But the e.sytwin offers much more....

please see our commercial documentation for full pump details.

## DESIGN FEATURES

- Water cooled motor and sound dampening casing creating the quietest booster pump available today
- Energy efficient variable speed motor operating from 0.25 KW to 1.5 KW
- Powerful performance Flow up to 3.3 Litres/second and head up to 6 Bar
- Self priming down to 8 Metres
- Dry running protection
- Frost protection
- Anti-vibration mountings
- Flexible installation with Horizontal or vertical position and wall mounting accessory kit
- Variable positions for in-let and out-let pipework
- Integrated chambers with expansion vessels, tool kit and installer manual
- Wireless connectivity and modular design can expand the pump system up to a 4 pump booster set
- Optional Integrated modular water storage tank system with Cat 5 connection (available April 2014)



## E.SYTWIN

## TECHNICAL DATA

MODEL	VOLTAGE	FREQUENCY	CONNECTION SIZE		ELECTRICAL DATA			
			SUCTION	DISCHARGE	MAX A	MAX POWER	PROTECTION CLASS	MOTOR CLASS
e.sytwin	220-240V / 1~	50/60 Hz	1 1/4" BSP F	1 1/4" BSP F	2 x 11 AMP	2 x 1550 W	IP44	F

## PERFORMANCE

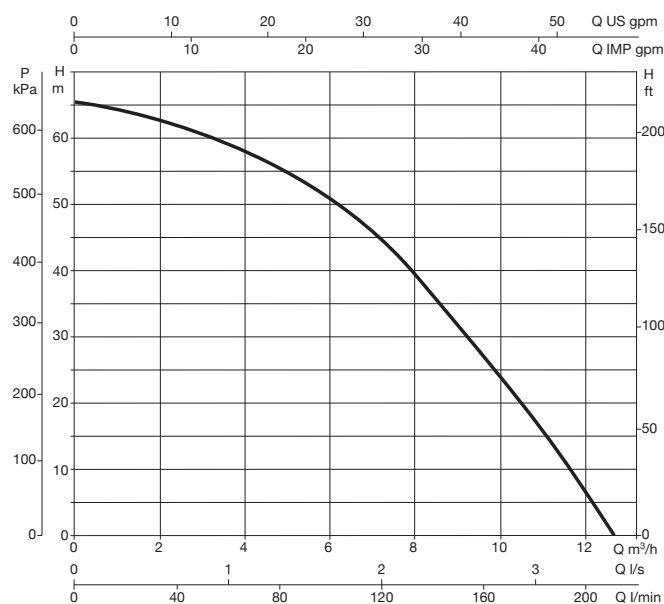

OVERALL DIMENSIONS			WEIGHT EMPTY	MAX WORKING PRESSURE	MAX LIQUID TEMPERATURE	MAX WORKING ENVIRONMENT
L	W	H				
753 mm	352 mm	729 mm	66 KG	8 Bar	+ 40 °C	+ 50 °C

### INTEGRATED SYSTEM PROTECTION INCLUDES:

- Protection against dry running ( Auto & manual reset options)
- Antifreeze protection
- Anticyling protection
- Motor overload protection
- Protection against abnormal supply voltages
- Protection against excessive temperatures

Maximum Flow: 200 Litres/Minute  
 Maximum Head: 60 Metres  
 Priming: 5 Mins at 8 Metres

See more about **e.sybox**  
[www.esybox.co.uk](http://www.esybox.co.uk)



DAB PUMPS Limited  
 Unit 4&5, Stortford Hall Ind Park,  
 Dunmow Road,  
 Bishops Stortford  
 Herts CM23 5GZ

[www.esybox.co.uk](http://www.esybox.co.uk)



# E.SYTWIN DIMENSIONS



# E.SYTWIN

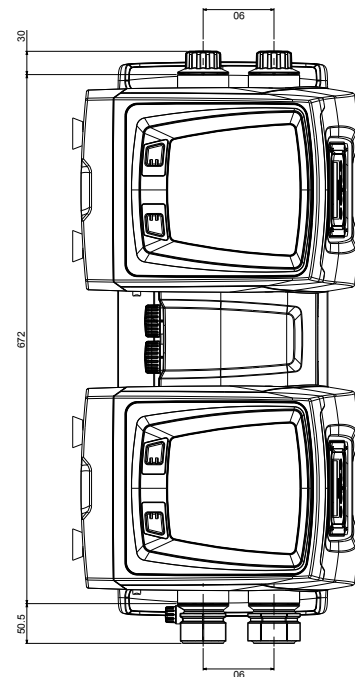
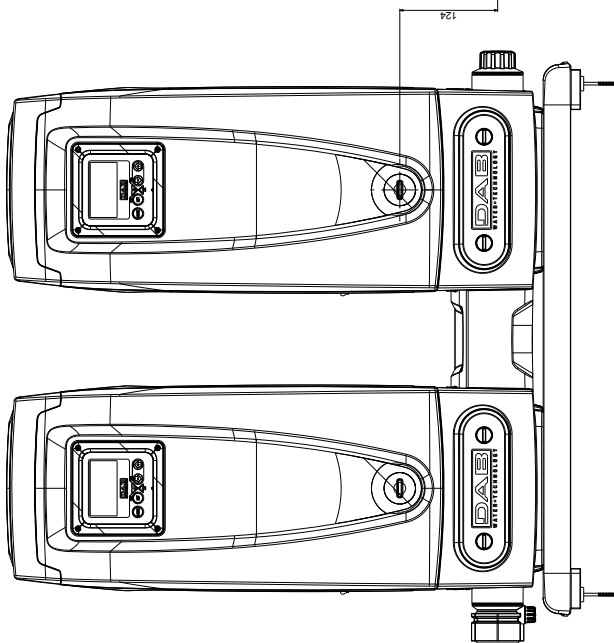
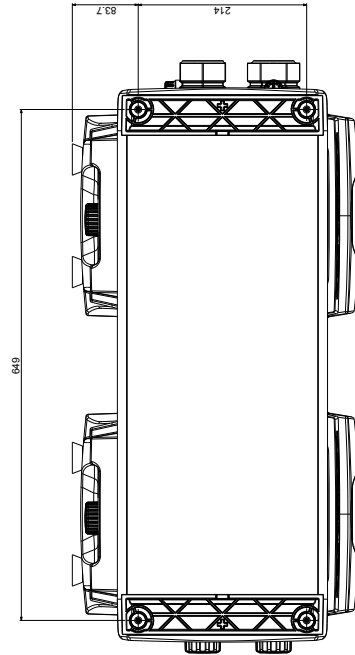
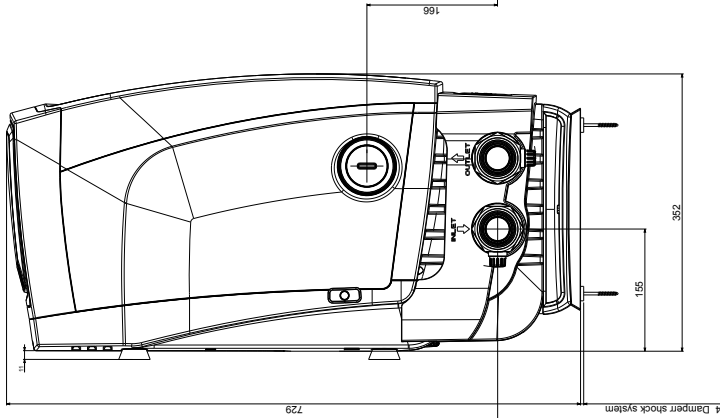
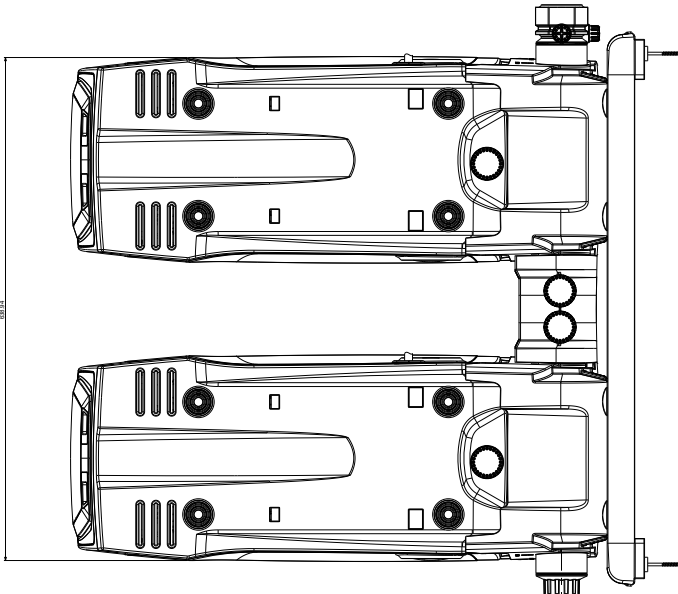

DAB PUMPS Limited  
 Unit 4&5, Stortford Hall Ind Park,  
 Dunmow Road,  
 Bishops Stortford  
 Herts CM23 5GZ

[www.esybox.co.uk](http://www.esybox.co.uk)

Tel: +44(0) 1279 652776  
 Fax: +44(0) 1279 657727  
 Email: [salesuk@dwtgroup.com](mailto:salesuk@dwtgroup.com)

